

Batteria al piombo 12V 100Ah - AGM



BP12-100

Caratteristiche Generali

Adatto per: Luci d'emergenza, Impianti d'allarme, UPS
Tecnologia: Piombo AGM

Caratteristiche Elettriche

Tensione: 12V
Capacità: 100Ah

Caratteristiche Meccaniche

Dimensioni: 172mm x 328mm x 222mm
Peso: 30Kg
Connessioni: a vite M8

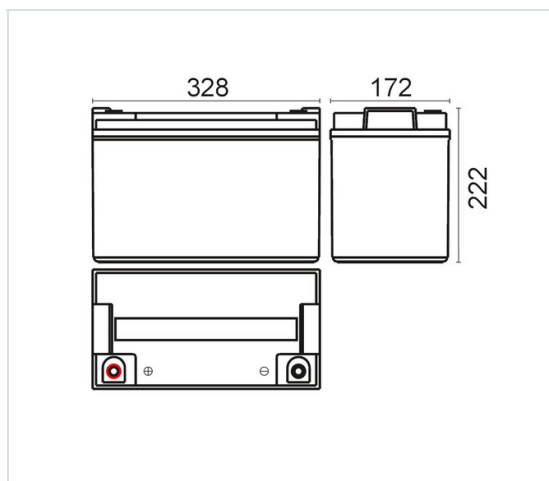

BP12-100

Batteria piombo AGM 12V 100Ah fis.vite

Confezione: Scatola da 1pz.

Prezzo per: unità

Multiplo di vendita: 1pz.



Connettori

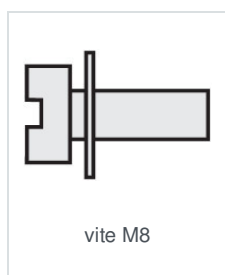

vite M8